

Application

The use of a corporation stop is required when the process water pipe cannot be drained at the diffuser to allow for maintenance. With a corporation stop, the diffuser can be removed while the process water pipe remains full and pressurized.

Sizes and Material Options

Sizes	Ball Valve	Solution Tube Assembly
1/2"	PVC, CPVC	PVC, CPVC
3/4"	Brass, PVC, CPVC	PVC, CPVC
1"	Brass, PVC, CPVC	PVC, CPVC, PVDF
1 1/4"	PVC, CPVC	PTFE, Stainless Steel
1 1/2"	Brass, PVC, CPVC	PVC, CPVC, Stainless Steel
2"	Brass	PVC, CPVC



Our no-lead brass corporation stop valves are certified to the requirements of NSF/ANSI 61 Annex F and G and NSF/ANSI 372. All other wetter materials in the corporation stop assembly are plastic.

Corporation stops are available with a variety of threaded and hose inlet connections. See Figures 2, 3, 4, and 5 for

Solution Tube Penetration Length

A corporation stop allows the injected chemical to enter the process water line away from the edge of the pipe. This facilitates more rapid and complete mixing for the injected chemical solution.

See Figure 1. It is recommended that the solution tube does not penetrate further than 1/3 of the process water line diameter. Please specify solution tube penetration length when ordering.

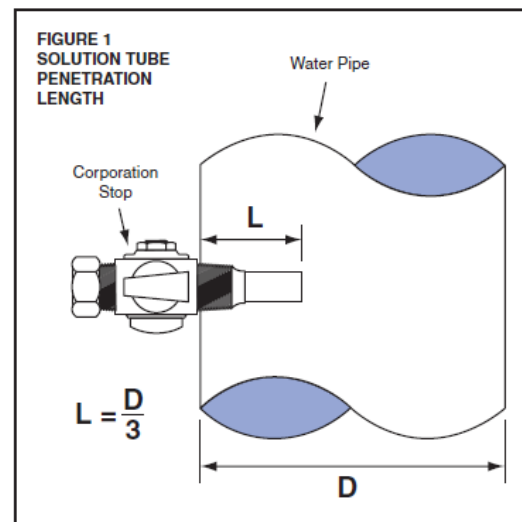

Installations

Any installation of a corporation stop must allow for sufficient clearance to remove the diffuser by pulling it toward the ejector after the nut has been loosened.

Rigid Pipe: See Figures 2 and 4. When using rigid pipe a shutoff valve and an elbow must be installed with a union after the turn. The shutoff valve will allow isolation of the section of pipe during removal. The union will allow withdrawal of the diffuser.

Hose: See Figures 3 and 5. Sufficient clearance must be available to remove the diffuser by pulling it toward the ejector after the nut has been loosened.

Safety Chain: The purpose of the safety chain is to prevent the solution diffuser from blowing out due to high pressure in the process water line after the nut has been loosened on the corporation stop. Take care when loosening the nut as the solution diffuser may be forced outward at high velocity. However, the safety chain will prevent the solution diffuser from coming completely out of the corporation stop. When the safety chain is taut, the corporation stop valve is to be closed. After this valve has been closed, the chain should be detached to allow removal of the solution diffuser assembly.

