



**GTI-DWT-550-1.9**  
550 GALLON HDPE DOUBLE WALL  
VERTICAL TANK 1.9SG

- This tank has a Diameter of 48" and Height of 84".
- Tank Capacity: 550 Gallons.
- Rated for storage of liquids up to 1.9 specific gravity (15.8 pounds per gallon).
- Molded from FDA approved High Density Polyethylene (HDPE).
- Complies with FDA standards 21 CFR 177.1520 (1) 3.1 and 3.2.
- HDPE has a maximum continuous use temperature of 130 F.
- This HDPE tank is approved for potable water.
- Meets ASTM D 1998-06 Wall Thickness Standard Specification for Polyethylene Upright Storage Tanks.
- Translucent White in color.
- Type of tank: DOUBLE WALL.
- This is an above ground tank. It is rated for atmospheric pressure only.
- Weight: 310 pounds.

**[www.GlobalTreat.com](http://www.GlobalTreat.com)**

[info@globaltreat.com](mailto:info@globaltreat.com)

281-370-3425



# GTI-DWT-550-1.9

550 GALLON HDPE DOUBLE WALL  
VERTICAL TANK 1.9SG

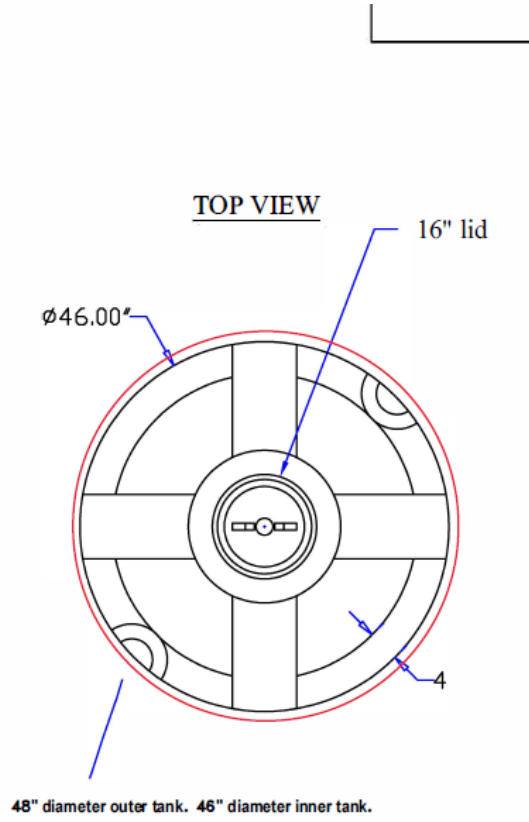
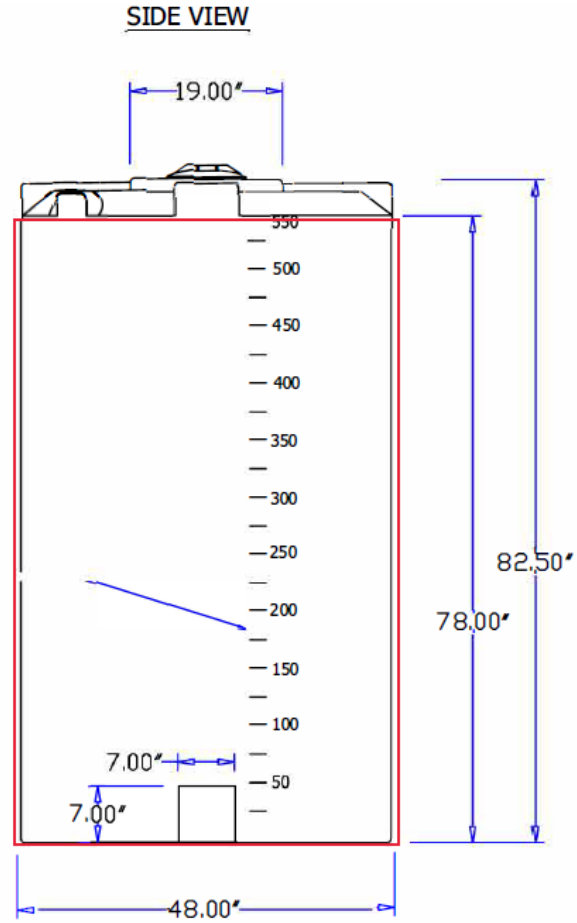

[www.GlobalTreat.com](http://www.GlobalTreat.com)  
info@globaltreat.com  
281-370-3425